

## ROLL STOCK FILM

**A WEB WIDTH**  
+/- 1/8" (~3mm)

**B REPEAT LENGTH**  
The length of one printed impression on the roll.

**C OUTSIDE DIAMETER**  
Outside diameter equal to or less than 12". Provide your maximum outside diameter (max OD) to ensure we produce the rolls at the right size. OD's that are too large can be difficult to maneuver or may not fit on the equipment.

**D CORE SIZE**  
3"

**QUANTITY**  
+/- 10%

We may produce and ship slightly above or below your desired quantity, therefore you may have a remaining balance if we produce and ship more, or be reimbursed if we produce and ship less.

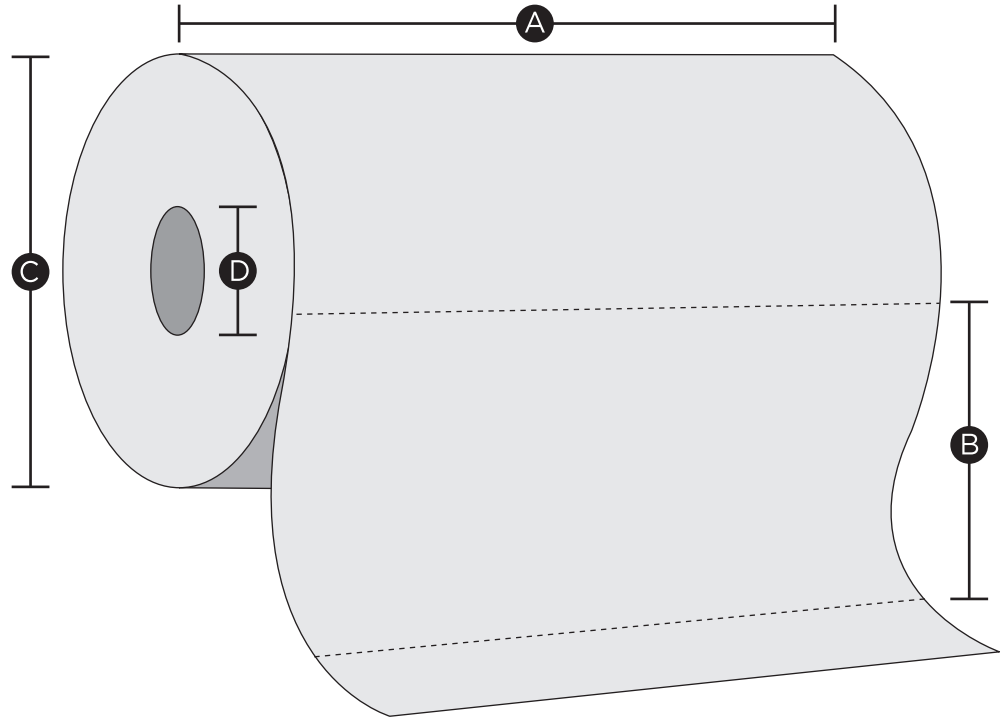

### REWIND DIRECTION

Also referred to as unwind direction, the rewind direction determines the orientation of the impression coming off the roll. Knowing your rewind direction ensures artwork reads the right way after it is formed and sealed.

Please be sure to select your rewind info before returning the signed form.

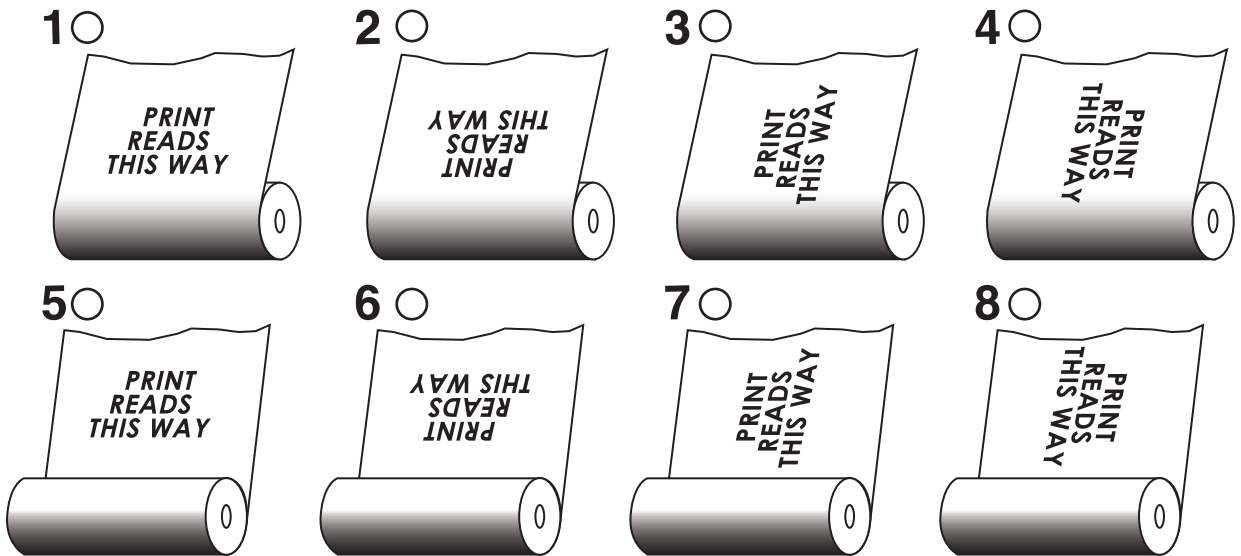

Signature: \_\_\_\_\_ Date: \_\_\_\_\_

\*Please complete and return the signed form to your sales representative. rev0621